

SFP+(CDR)-10G-15-40K-D(I)

10Gb/s 1550nm SFP+ 40km Transceiver with/without CDR

PRODUCT FEATURES

- Up to 11.3Gbps Data Links
- Up to 40km transmission on SMF
- EML transmitter and PIN receiver
- Metal enclosure for lower EMI
- 2-wire interface with integrated Digital Diagnostic monitoring
- Hot-pluggable SFP+ footprint
- Specifications compliant with SFF-8472
- Compliant with SFP+ MSA with LC connector
- Single 3.3V power supply
- Commercial/Industrial case operating temperature range: 0°C to 70°C / -40°C to 85°C
- Without CDR or with CDR supported 9.95 to 11.3Gb/s reference-free
- Low power dissipation:

SFP+10G-15-40K-D: 1.2W power dissipation without CDR for Commercial temperature

SFP+10G-15-40K-DI: 1.4W power dissipation without CDR for Industrial temperature

SFP+CDR-10G-15-40K-D: 1.3W power dissipation with CDR for Commercial temperature

SFP+CDR-10G-15-40K-DI: 1.5W power dissipation with CDR for Industrial temperature

APPLICATIONS

- 10GBASE-ER/EW & 10G Ethernet
- 10G SONET/SDH, OTU2/2e

STANDARD

- Compliant to SFF-8431
- Compliant to SFF 8472
- RoHS Compliant.



INDONESIA OFFICE 
WEST PARK B-23
JL. BLVD. BARAT BSD CITY
PAGEDANGAN, TANGERANG
BANTEN 15336
+62 2 150 858 721

HEAD OFFICE AND R&D LAB
UNIT 1 / 6 POWELLS ROAD
BROOKVALE, SYDNEY
NSW 2100 AUSTRALIA
 +61 2 8078 2207

MELBOURNE OFFICE
11 CORPORATE DRIVE
CRANBOURNE WEST
VIC 3977 AUSTRALIA
 +61 3 8679 4575

USA R&D LAB
48233
WARM SPRINGS BLVD.
FREMONT CA
 +1 510 945 1001
+1 510 298 5772

Ordering Information

Product Part Number	Media	Wavelength (nm)	Transmission Distance (km)	Temperature Range(TCASE) (°C)	With/Without CDR
SFP+10G-15-40K-D	Single-mode fibre	1550	40	0~70	Without CDR
SFP+10G-15-40K-DI	Single-mode fibre	1550	40	-40~85	Without CDR
SFP+CDR-10G-15-40K-D	Single-mode fibre	1550	40	0~70	With CDR
SFP+CDR-10G-15-40K-DI	Single-mode fibre	1550	40	-40~85	With CDR

Product Selection

Cloudtron SFP+(CDR)-10G-15-40K-D(I) serial SFP+ transceiver is designed for use in 10-Gigabit Ethernet links up to 40km over single mode fibre. The module consists of 1550 EML Laser, InGaAs PIN and Preamplifier in a high-integrated optical sub-assembly. Digital diagnostics functions are available via a 2-wire serial interface, as specified in SFF-8472. The module data link up to 40km in 9/125um single mode fibre.

INDONESIA OFFICE

WEST PARK B-23
JL. BLVD. BARAT BSD CITY
PAGEDANGAN, TANGERANG

 BANTEN 15336
+62 2 150 858 721

HEAD OFFICE AND R&D LAB

UNIT 1 / 6 POWELLS ROAD
BROOKVALE, SYDNEY
NSW 2100 AUSTRALIA

 +61 2 8078 2207

MELBOURNE OFFICE

11 CORPORATE DRIVE
CRANBOURNE WEST
VIC 3977 AUSTRALIA

 +61 3 8679 4575

USA R&D LAB

48233
WARM SPRINGS BLVD.
FREMONT CA

 +1 510 945 1001
+1 510 298 5772

I. Absolute Maximum Ratings

Parameter	Symbol	Min.	Typ.	Max.	Unit
Storage Temperature	Ts	-40	-	85	°C
Relative Humidity	RH	5	-	95	%
Power Supply Voltage	Vcc	-0.3	-	4	V
Signal Input Voltage		Vcc-0.3	-	Vcc+0.3	V

II. Recommended Operating Conditions

Parameter	Symbol	Min.	Typ.	Max.	Unit	Note	
Case Operating Temperature	Top	0	-	70	°C	SFP+10G-15-40K-D SFP+CDR-10G-15-40K-D	
		-40		85		SFP+10G-15-40K-DI SFP+CDR-10G-15-40K-DI	
Power Supply Voltage	Vcc	3.14	3.3	3.47	V		
Data Rate	BR		10.3125	11.3	Gbps		
Max transmission Distance	TD		40		km		
Coupled fibre	Single mode fibre						9/125um SMF

III. Optical Characteristics

Parameter	Symbol	Min.	Typ.	Max.	Unit	Note
Transmitter						
Average Launched Power	PO	-1		+3	dBm	Note (1)
Extinction Ratio	ER	8.2			dB	
Centre Wavelength	λ_c	1530	1550	1565	nm	
Spectrum Band Width (-20dB)	σ			1.0	nm	
SMSR		30			dB	
Transmitter OFF Output Power	POff			-30	dBm	
Transmitter and Dispersion Penalty	TDP			2.0	dB	
Output Eye Mask	Compliant with IEEE 802.3ae					
Receiver						
Input Optical Wavelength	λ	1270		1610	nm	
Receiver Sensitivity	P _{sen}			-16.0	dBm	Note (2)
Input Saturation Power (Overload)	P _{sat}	0			dBm	
LOS Assert	LOSA	-30			dBm	
LOS De-assert	LOSD			-17	dBm	
LOS Detect Hysteresis	P _{hys}	0.5			dB	

Note:

1. Launched power (avg.) is power coupled into a single mode fibre with master connector (Before of Life).
2. Measured with conformance test signal for BER = 10⁻¹².@10.3125Gbps, PRBS=2³¹-1,NRZ ; Optical source with worst ER, Wavelength between 1530nm and 1565nm ; back to back.

IV. Electrical Characteristics

Parameter	Symbol	Min	Typ.	Max	Unit	Note
Supply Voltage	V _{CC}	3.14	3.3	3.46	V	
Supply Current (Note 1)	I _{CC}			370	mA	SFP+10G-15-40K-D
				430		SFP+10G-15-40K-DI
				400		SFP+CDR-10G-15-40K-D
				460		SFP+CDR-10G-15-40K-DI
Transmitter						
Input differential impedance	R _{in}		100		Ω	2
Single ended data input swing	V _{in-pp}	180		700	mV	
Transmit Disable Voltage	V _{Dis}	2.0		V _{CC}	V	3
Transmit Enable Voltage	V _{EN}	V _{EE}		V _{EE} + 0.8	V	
Transmit Disable Assert Time				10	us	
Receiver						
Differential data output swing	V _{out-pp}	400		800	mV	4
Data output rise time	t _r	28			ps	5
Data output fall time	t _f	28			ps	5
LOS output high level	V _{LOS-H}	2.0		V _{CC} HOST	V	6
LOS output low level	V _{LOS-L}	V _{EE}		V _{EE} +0.8	V	6
Power Supply Rejection	PSR	100			mVpp	7

Note:

1. Measured with receive Pin=Psen, V_{CC}=3.3V, operation temperature range, without air flow
2. Connected directly to TX data input pins. AC coupled.
3. Or open circuit.
4. Into 100 Ohms differential termination.
5. 20 – 80 %.
6. Loss of Signal is LVTTTL. Logic 0 indicates normal operation; logic 1 indicates no signal detected.
7. Receiver sensitivity is compliant with power supply sinusoidal modulation of 20 Hz to 1.5 MHz up to specified value applied through the recommended power supply filtering network.

INDONESIA OFFICE 
 WEST PARK B-23
 JL. BLVD. BARAT BSD CITY
 PAGEDANGAN, TANGERANG
 BANTEN 15336
 +62 2 150 858 721

HEAD OFFICE AND R&D LAB
 UNIT 1 / 6 POWELLS ROAD
 BROOKVALE, SYDNEY
 NSW 2100 AUSTRALIA
 +61 2 8078 2207

MELBOURNE OFFICE
 11 CORPORATE DRIVE
 CRANBOURNE WEST
 VIC 3977 AUSTRALIA
 +61 3 8679 4575

USA R&D LAB
 48233
 WARM SPRINGS BLVD.
 FREMONT CA
 +1 510 945 1001
 +1 510 298 5772

V. Pin Description

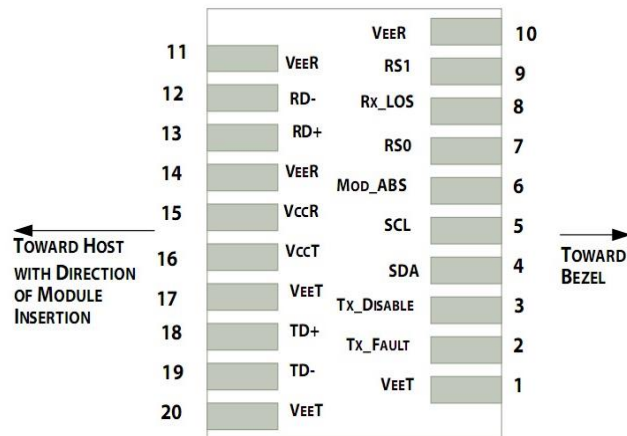

Pin out of Connector Block on Host Board

Pin	Symbol	Name/Description	Note
1	V _{EET}	Transmitter Ground (Common with Receiver Ground)	1
2	T _{FAULT}	Transmitter Fault.	2
3	T _{DIS}	Transmitter Disable. Laser output disabled on high or open.	3
4	SDA	2-wire Serial Interface Data Line	4
5	SCL	2-wire Serial Interface Clock Line	4
6	MOD_ABS	Module Absent. Grounded within the module	4
7	RS0	no connection	
8	LOS	Loss of Signal indication. Logic 0 indicates normal operation.	5
9	RS1	Internally connect to circuit ground	
10	V _{EER}	Receiver Ground (Common with Transmitter Ground)	1
11	V _{EER}	Receiver Ground (Common with Transmitter Ground)	1
12	RD-	Receiver Inverted DATA out. AC Coupled	
13	RD+	Receiver Non-inverted DATA out. AC Coupled	
14	V _{EER}	Receiver Ground (Common with Transmitter Ground)	1
15	V _{CCR}	Receiver Power Supply	
16	V _{CCT}	Transmitter Power Supply	
17	V _{EET}	Transmitter Ground (Common with Receiver Ground)	1
18	TD+	Transmitter Non-Inverted DATA in. AC Coupled.	
19	TD-	Transmitter Inverted DATA in. AC Coupled.	
20	V _{EET}	Transmitter Ground (Common with Receiver Ground)	1

Note:

1. Circuit ground is internally isolated from chassis ground.
2. T_{FAULT} is an LVTTTL output. A high output indicates a transmitter fault caused by either the TX bias current or FAULT the TX output power or the laser temperature exceeding the preset alarm thresholds. A low output indicates normal operation. In the low state, the output is pulled to <0.8V.
3. Laser output disabled on T_{DIS} >2.0V or open, enabled on T_{DIS} <0.8V.
4. Should be pulled up with 4.7kΩ- 10kΩ on host board to a typical 3.3V voltage. MOD_ABS pulls low to indicate module is plugged in.
5. LOS is open collector output. It should be pulled up with 4.7kΩ – 10kΩ on host board to a typical 3.3V voltage. Logic 0 indicates normal operation; logic 1 indicates loss of signal.

VI. Digital Diagnostic Functions

Cloudtron SFP+(CDR)-10G-15-40K-D(I) serial transceivers support the 2-wire serial communication protocol as defined in the SFP+MSA. The standard SFP serial ID provides access to identification information that describes the transceiver's capabilities, standard interfaces, manufacturer, and other information.

Additionally, Cloudtron SFP+ transceivers provide a unique enhanced digital diagnostic monitoring interface, which allows real-time access to device operating parameters such as transceiver temperature, laser bias current, transmitted optical power, received optical power and transceiver supply voltage. It also defines a sophisticated system of alarm and warning flags, which alerts end-users when particular operating parameters are outside of a factory set normal range.

The SFP MSA defines a 256-byte memory map in EEPROM that is accessible over a 2-wire serial interface at the 8bit address 1010000X (A0h). The digital diagnostic monitoring interface makes use of the 8bit address 1010001X (A2h), so the originally defined serial ID memory map remains unchanged.

The operating and diagnostics information is monitored and reported by a Digital Diagnostics Transceiver Controller (DDTC) inside the transceiver, which is accessed through a 2-wire serial interface. When the serial protocol is activated, the serial clock signal (SCL, Mod Def 1) is generated by the host. The positive edge clocks data into the SFP transceiver into those segments of the E2PROM that are not write-protected. The negative edge clocks data from the SFP transceiver. The serial data signal (SDA, Mod Def 2) is bi-directional for serial data transfer. The host uses SDA in conjunction with SCL to mark the start and end of serial protocol activation. The memories are organized as a series of 8-bit data words that can be addressed individually or sequentially.

INDONESIA OFFICE

WEST PARK B-23
JL. BLVD. BARAT BSD CITY
PAGEDANGAN, TANGERANG

 BANTEN 15336
+62 2 150 858 721

HEAD OFFICE AND R&D LAB

UNIT 1 / 6 POWELLS ROAD
BROOKVALE, SYDNEY
NSW 2100 AUSTRALIA

 +61 2 8078 2207

MELBOURNE OFFICE

11 CORPORATE DRIVE
CRANBOURNE WEST
VIC 3977 AUSTRALIA

 +61 3 8679 4575

USA R&D LAB

48233
WARM SPRINGS BLVD.
FREMONT CA

 +1 510 945 1001
+1 510 298 5772

VII. Recommended Interface Circuit

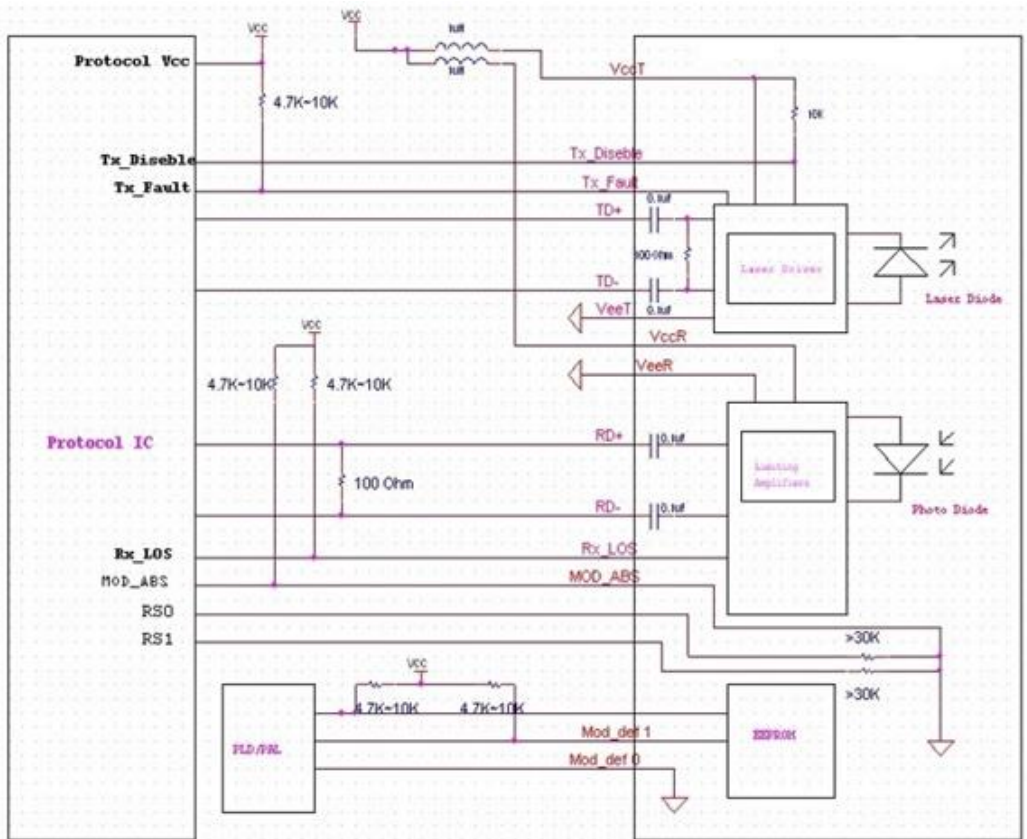

VIII. Outline Dimensions

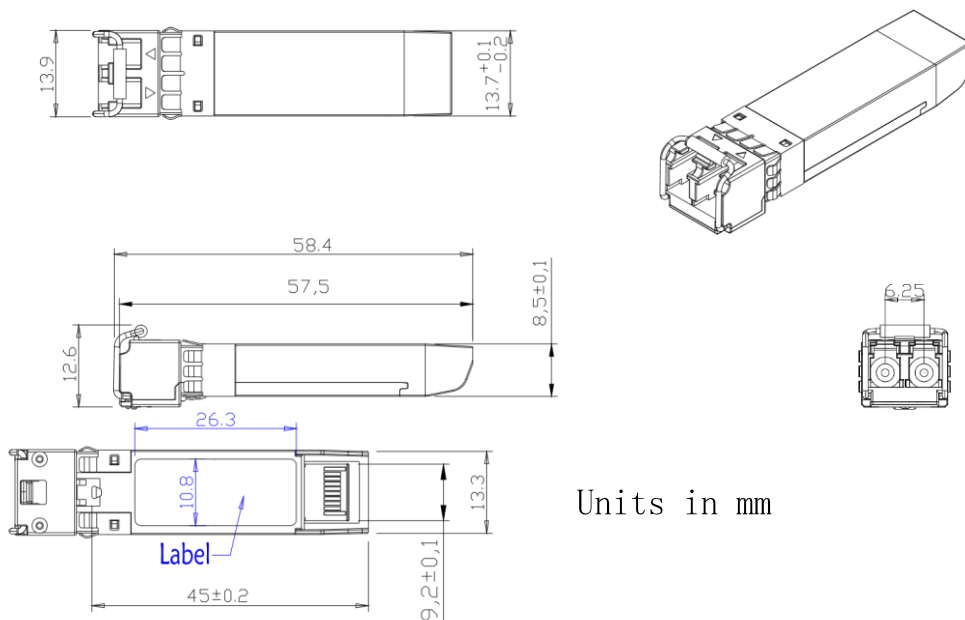

INDONESIA OFFICE 
 WEST PARK B-23
 JL. BLVD. BARAT BSD CITY
 PAGEDANGAN, TANGERANG
 BANTEN 15336
 +62 2 150 858 721

HEAD OFFICE AND R&D LAB
 UNIT 1 / 6 POWELLS ROAD
 BROOKVALE, SYDNEY
 NSW 2100 AUSTRALIA
 +61 2 8078 2207

MELBOURNE OFFICE
 11 CORPORATE DRIVE
 CRANBOURNE WEST
 VIC 3977 AUSTRALIA
 +61 3 8679 4575

USA R&D LAB
 48233
 WARM SPRINGS BLVD.
 FREMONT CA
 +1 510 945 1001
 +1 510 298 5772

IX. Regulatory Compliance

Feature	Reference	Performance
Electrostatic discharge (ESD)	IEC/EN 61000-4-2	Compatible with standards
Electromagnetic Interference (EMI)	FCC Part 15 Class B EN 55022 Class B (CISPR 22A)	Compatible with standards
Laser Eye Safety	FDA 21CFR 1040.10, 1040.11 IEC/EN 60825-1, 2	Class 1 laser product
Component Recognition	IEC/EN 60950, UL	Compatible with standards
ROHS	2002/95/EC	Compatible with standards
EMC	EN61000-3	Compatible with standards

INDONESIA OFFICE

WEST PARK B-23
JL. BLVD. BARAT BSD CITY
PAGEDANGAN, TANGERANG



BANTEN 15336
+62 2 150 858 721



HEAD OFFICE AND R&D LAB

UNIT 1 / 6 POWELLS ROAD
BROOKVALE, SYDNEY
NSW 2100 AUSTRALIA



+61 2 8078 2207

MELBOURNE OFFICE

11 CORPORATE DRIVE
CRANBOURNE WEST
VIC 3977 AUSTRALIA



+61 3 8679 4575

USA R&D LAB

48233
WARM SPRINGS BLVD.
FREMONT CA



+1 510 945 1001
+1 510 298 5772