

## SFP-1G-85-550M-D(I)

### 1.25Gb/s 850nm Multi-mode SFP Transceiver

#### PRODUCT FEATURES

- ☁ Up to 1.25Gb/s data links with DDM
- ☁ VCSEL laser transmitter and PIN photo-detector
- ☁ Hot-pluggable SFP footprint
- ☁ Duplex LC/UPC type pluggable optical interface
- ☁ Low power dissipation
- ☁ Metal enclosure, for lower EMI
- ☁ RoHS compliant and lead-free
- ☁ Single +3.3V power supply
- ☁ Compliant with SFF-8472
- ☁ Case operating temperature: Commercial: 0°C to +70°C  
Industrial: -40°C to +85°C



#### APPLICATIONS

- ☁ 1x Fibre Channel
- ☁ Switch to Switch Interface
- ☁ Gigabit Ethernet
- ☁ Switched Backplane Applications
- ☁ Router/Server Interface
- ☁ Other Optical Links

INDONESIA OFFICE **NEW**  
WEST PARK B-23  
JL. BLVD. BARAT BSD CITY  
PAGEDANGAN, TANGERANG  
BANTEN 15336  
+62 2 150 858 721

HEAD OFFICE AND R&D LAB  
UNIT 1 / 6 POWELLS ROAD  
BROOKVALE, SYDNEY  
NSW 2100 AUSTRALIA  
 +61 2 8078 2207

MELBOURNE OFFICE  
11 CORPORATE DRIVE  
CRANBOURNE WEST  
VIC 3977 AUSTRALIA  
 +61 3 8679 4575

USA R&D LAB  
48233  
WARM SPRINGS BLVD.  
FREMONT CA  
 +1 510 945 1001  
 +1 510 298 5772

## Product Description

Cloudtron SFP-1G-85-550-D Small Form Factor Pluggable (SFP) transceivers are compatible with the Small Form Factor Pluggable Multi-Sourcing Agreement (MSA). The transceiver consists of five sections: the LD driver, the limiting amplifier, the digital diagnostic monitor, the VCSEL laser and the PIN photo-detector. The module data link up to 550m in 50/125um multi-mode fibre.

The optical output can be disabled by a TTL logic high-level input of Tx Disable, and the system also can disable the module via I2C. Tx Fault is provided to indicate that degradation of the laser. Loss of signal (LOS) output is provided to indicate the loss of an input optical signal of receiver or the link status with partner. The system can also get the LOS (or Link)/Disable/Fault information via I2C register access.

## Ordering Information

Product part Number	Data Rate (Mbps)	Media	Wavelength (nm)	Transmission Distance(m)	Temperature Range (Tcase) (°C)	
<b>SFP-1G-85-550M-D</b>	1250	Multi-mode fibre	850	550	0~70	Commercial
<b>SFP-1G-85-550M-DI</b>	1250	Multi-mode fibre	850	550	-40~85	Industrial

**INDONESIA OFFICE**   
 WEST PARK B-23  
 JL. BLVD. BARAT BSD CITY  
 PAGEDANGAN, TANGERANG  
 BANTEN 15336  
 +62 2 150 858 721

**HEAD OFFICE AND R&D LAB**  
 UNIT 1 / 6 POWELLS ROAD  
 BROOKVALE, SYDNEY  
 NSW 2100 AUSTRALIA  
 +61 2 8078 2207

**MELBOURNE OFFICE**  
 11 CORPORATE DRIVE  
 CRANBOURNE WEST  
 VIC 3977 AUSTRALIA  
 +61 3 8679 4575

**USA R&D LAB**  
 48233  
 WARM SPRINGS BLVD.  
 FREMONT CA  
 +1 510 945 1001  
 +1 510 298 5772

## I. Pin Descriptions

Pin	Symbol	Name/Description	Note
1	VEET	Transmitter Ground (Common with Receiver Ground)	1
2	TFAULT	Transmitter Fault.	
3	TDIS	Transmitter Disable. Laser output disabled on high or open.	2
4	MOD_DEF(2)	Module Definition 2. Data line for Serial ID.	3
5	MOD_DEF(1)	Module Definition 1. Clock line for Serial ID.	3
6	MOD_DEF(0)	Module Definition 0. Grounded within the module.	3
7	Rate Select	No connection required	4
8	LOS	Loss of Signal indication. Logic 0 indicates normal operation.	5
9	VEER	Receiver Ground (Common with Transmitter Ground)	1
10	VEER	Receiver Ground (Common with Transmitter Ground)	1
11	VEER	Receiver Ground (Common with Transmitter Ground)	1
12	RD-	Receiver Inverted DATA out. AC Coupled	
13	RD+	Receiver Non-inverted DATA out. AC Coupled	
14	VEER	Receiver Ground (Common with Transmitter Ground)	1
15	VCCR	Receiver Power Supply	
16	VCCT	Transmitter Power Supply	
17	VEET	Transmitter Ground (Common with Receiver Ground)	1
18	TD+	Transmitter Non-Inverted DATA in. AC Coupled.	
19	TD-	Transmitter Inverted DATA in. AC Coupled.	
20	VEET	Transmitter Ground (Common with Receiver Ground)	1

Note:

- Circuit ground is internally isolated from chassis ground.
- Laser output disabled on  $T_{DIS} > 2.0V$  or open, enabled on  $T_{DIS} < 0.8V$ .
- Should be pulled up with 4.7k - 10kohms on host board to a voltage between 2.0V and 3.6V. MOD\_DEF (0) pulls line low to indicate module is plugged in.
- This is an optional input used to control the receiver bandwidth for compatibility with multiple data rates (most likely Fibre Channel 1x and 2x Rates). If implemented, the input will be internally pulled down with  $> 30k\Omega$  resistor. The input states are:
  - Low (0 – 0.8V): Reduced Bandwidth
  - (>0.8, < 2.0V): Undefined
  - High (2.0 – 3.465V): Full Bandwidth
  - Open: Reduced Bandwidth
- LOS is open collector output should be pulled up with 4.7k - 10kohms on host board to a voltage between 2.0V and 3.6V. Logic 0 indicates normal operation; logic 1 indicates loss of signal.

**INDONESIA OFFICE**   
 WEST PARK B-23  
 JL. BLVD. BARAT BSD CITY  
 PAGEDANGAN, TANGERANG  
 BANTEN 15336  
 +62 2 150 858 721

**HEAD OFFICE AND R&D LAB**  
 UNIT 1 / 6 POWELLS ROAD  
 BROOKVALE, SYDNEY  
 NSW 2100 AUSTRALIA  
 +61 2 8078 2207

**MELBOURNE OFFICE**  
 11 CORPORATE DRIVE  
 CRANBOURNE WEST  
 VIC 3977 AUSTRALIA  
 +61 3 8679 4575

**USA R&D LAB**  
 48233  
 WARM SPRINGS BLVD.  
 FREMONT CA  
 +1 510 945 1001  
 +1 510 298 5772

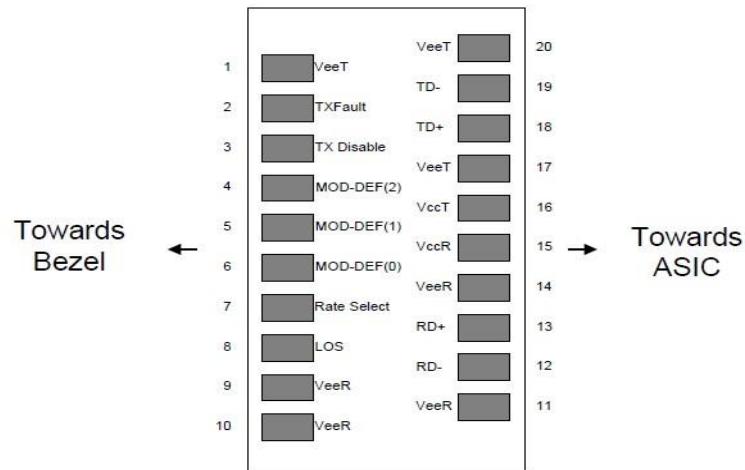

Figure2. Pin out of Connector Block on Host Board

## II. Absolute Maximum Ratings

Parameter	Symbol	Min.	Typ.	Max.	Unit
Storage Temperature	Ts	-40		85	°C
Relative Humidity	RH	5		95	%
Power Supply Voltage	VCC	-0.5		4	V
Signal Input Voltage		-0.3		Vcc+0.3	V
Receiver Damage Threshold		+5			dBm

## III. Recommended Operating Conditions

Parameter	Symbol	Min.	Typ.	Max.	Unit	Note
Case Operating Temperature	Tcase	0		70	°C	SFP-1G-85-550M-D
		-40		85		SFP-1G-85-550M-DI
Power Supply Voltage	VCC	3.13	3.3	3.47	V	
Power Supply Current	ICC			280	mA	
Data Rate			1250/1250		Mbps	TX Rate/RX Rate
Transmission Distance				550	M	
Coupled Fibre		Multi-mode fibre				50/125um MMF

INDONESIA OFFICE   
 WEST PARK B-23  
 JL. BLVD. BARAT BSD CITY  
 PAGEDANGAN, TANGERANG  
 BANTEN 15336  
 +62 2 150 858 721

HEAD OFFICE AND R&D LAB  
 UNIT 1 / 6 POWELLS ROAD  
 BROOKVALE, SYDNEY  
 NSW 2100 AUSTRALIA  
 +61 2 8078 2207

MELBOURNE OFFICE  
 11 CORPORATE DRIVE  
 CRANBOURNE WEST  
 VIC 3977 AUSTRALIA  
 +61 3 8679 4575

USA R&D LAB  
 48233  
 WARM SPRINGS BLVD.  
 FREMONT CA  
 +1 510 945 1001  
 +1 510 298 5772

#### IV. Specification of Transmitter

Parameter	Symbol	Min.	Typ.	Max.	Unit	Note
Average Output Power	POUT	-9		-3	dBm	1
Extinction Ratio	ER	9			dB	
Centre Wavelength	$\lambda_c$	770	850	860	nm	VCSEL Laser
Spectrum Bandwidth (RMS)	$\sigma$			0.85	nm	
Transmitter OFF Output Power	POff			-45	dBm	
Differential Line Input Impedance	RIN	90	100	110	Ohm	
Output Eye Mask	Compliant with IEEE802.3 z (class 1 laser safety)					2

Note 1: Measure at 2<sup>7</sup>-1 NRZ PRBS pattern

Note 2: Transmitter eye mask definition

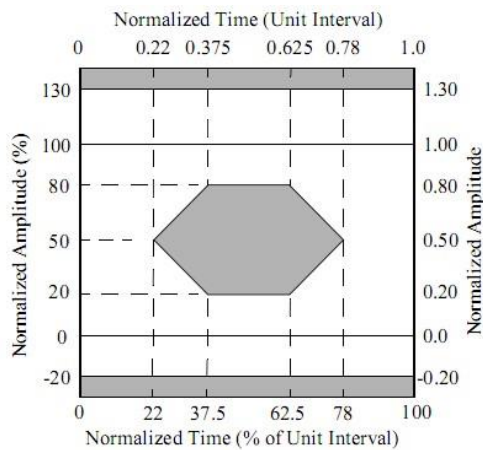

#### V. Specification of Receiver

Parameter	Symbol	Min.	Typ.	Max.	Unit	Note
Input Optical Wavelength	$\lambda_{IN}$	770	850	860	nm	PIN-TIA
Receiver Sensitivity	PIN			-17	dBm	1
Input Saturation Power (Overload)	PSAT	0			dBm	
LOS De-assert	LOSD			-18	dBm	
LOS Assert	LOSA	-35			dBm	2
LOS Hysteresis		0.5	2	6	dB	

Note 1: Measured with Light source 850nm, ER=9dB; BER =<10<sup>-12</sup> @PRBS=2<sup>7</sup>-1 NRZ

Note 2: When LOS de-asserted, the RX data+/- output is High-level (fixed)

INDONESIA OFFICE **NEW**  
 WEST PARK B-23  
 JL. BLVD. BARAT BSD CITY  
 PAGEDANGAN, TANGERANG  
 BANTEN 15336  
 +62 2 150 858 721

HEAD OFFICE AND R&D LAB  
 UNIT 1 / 6 POWELLS ROAD  
 BROOKVALE, SYDNEY  
 NSW 2100 AUSTRALIA  
 +61 2 8078 2207

MELBOURNE OFFICE  
 11 CORPORATE DRIVE  
 CRANBOURNE WEST  
 VIC 3977 AUSTRALIA  
 +61 3 8679 4575

USA R&D LAB  
 48233  
 WARM SPRINGS BLVD.  
 FREMONT CA  
 +1 510 945 1001  
 +1 510 298 5772



## VI. Electrical Interface Characteristics

Parameter	Symbol	Min.	Typ.	Max.	Unit	Note
<b>Transmitter</b>						
<b>Total Supply Current</b>	ICC			A	mA	1
<b>Transmitter Disable Input-High</b>	VDISH	2		V <sub>CC</sub> +0.3	V	
<b>Transmitter Disable Input-Low</b>	VDISL	0		0.8	V	
<b>Transmitter Fault Input-High</b>	VTxFH	2		V <sub>CC</sub> +0.3	V	
<b>Transmitter Fault Input-Low</b>	VTxFL	0		0.8	V	
<b>Receiver</b>						
<b>Total Supply Current</b>	ICC			B	mA	1
<b>LOSS Output Voltage-High</b>	VLOSH	2		V <sub>CC</sub> +0.3	V	LVTTTL
<b>LOSS Output Voltage-Low</b>	VLOSL	0		0.8	V	

Note 1: A (TX) + B (RX) = 280mA (Not include termination circuit)

## VII. Digital Diagnostic Functions

Cloudtron SFP-1G-85-550M-D(I) transceivers support the 2-wire serial communication protocol as defined in the SFP MSA. It is very closely related to the E2PROM defined in the GBIC standard, with the same electrical specifications. The standard SFP serial ID provides access to identification information that describes the transceiver's capabilities, standard interfaces, manufacturer, and other information.

Additionally, Cloudtron SFP transceivers provide a unique enhanced digital diagnostic monitoring interface, which allows real-time access to device operating parameters such as transceiver temperature, laser bias current, transmitted optical power, received optical power and transceiver supply voltage. It also defines a sophisticated system of alarm and warning flags, which alerts end-users when particular operating parameters are outside of a factory set normal range.

The SFP MSA defines a 256-byte memory map in E2PROM that is accessible over a 2-wire serial interface at the 8 bit address 1010000X (A0h). The digital diagnostic monitoring interface makes use of the 8 bit address 1010001X (A2h), so the originally defined serial ID memory map remains unchanged. The interface is identical to, and is thus fully backward compatible with both the GBIC Specification and the SFP Multi Source Agreement.

The operating and diagnostics information is monitored and reported by a Digital Diagnostics Transceiver Controller (DDTC) inside the transceiver, which is accessed through a 2-wire serial interface. When the serial protocol is activated, the serial clock signal (SCL, Mod Def 1) is generated by the host. The positive edge clocks data into the SFP transceiver into those segments of the E2PROM that are not write-protected. The negative edge clocks data from the SFP transceiver. The serial data signal (SDA, Mod Def 2) is bi-directional for serial data transfer. The host uses SDA in conjunction with SCL to mark the start and end of serial protocol activation. The memories are organized as a series of 8-bit data words that can be addressed individually or sequentially.

**INDONESIA OFFICE**   
 WEST PARK B-23  
 JL. BLVD. BARAT BSD CITY  
 PAGEDANGAN, TANGERANG  
 BANTEN 15336  
 +62 2 150 858 721

**HEAD OFFICE AND R&D LAB**  
 UNIT 1 / 6 POWELLS ROAD  
 BROOKVALE, SYDNEY  
 NSW 2100 AUSTRALIA  
 +61 2 8078 2207

**MELBOURNE OFFICE**  
 11 CORPORATE DRIVE  
 CRANBOURNE WEST  
 VIC 3977 AUSTRALIA  
 +61 3 8679 4575

**USA R&D LAB**  
 48233  
 WARM SPRINGS BLVD.  
 FREMONT CA  
 +1 510 945 1001  
 +1 510 298 5772

Digital diagnostics for the SFP-1G-85-550M-D(I) are internally calibrated by default.

### VIII. Recommend Circuit Schematic

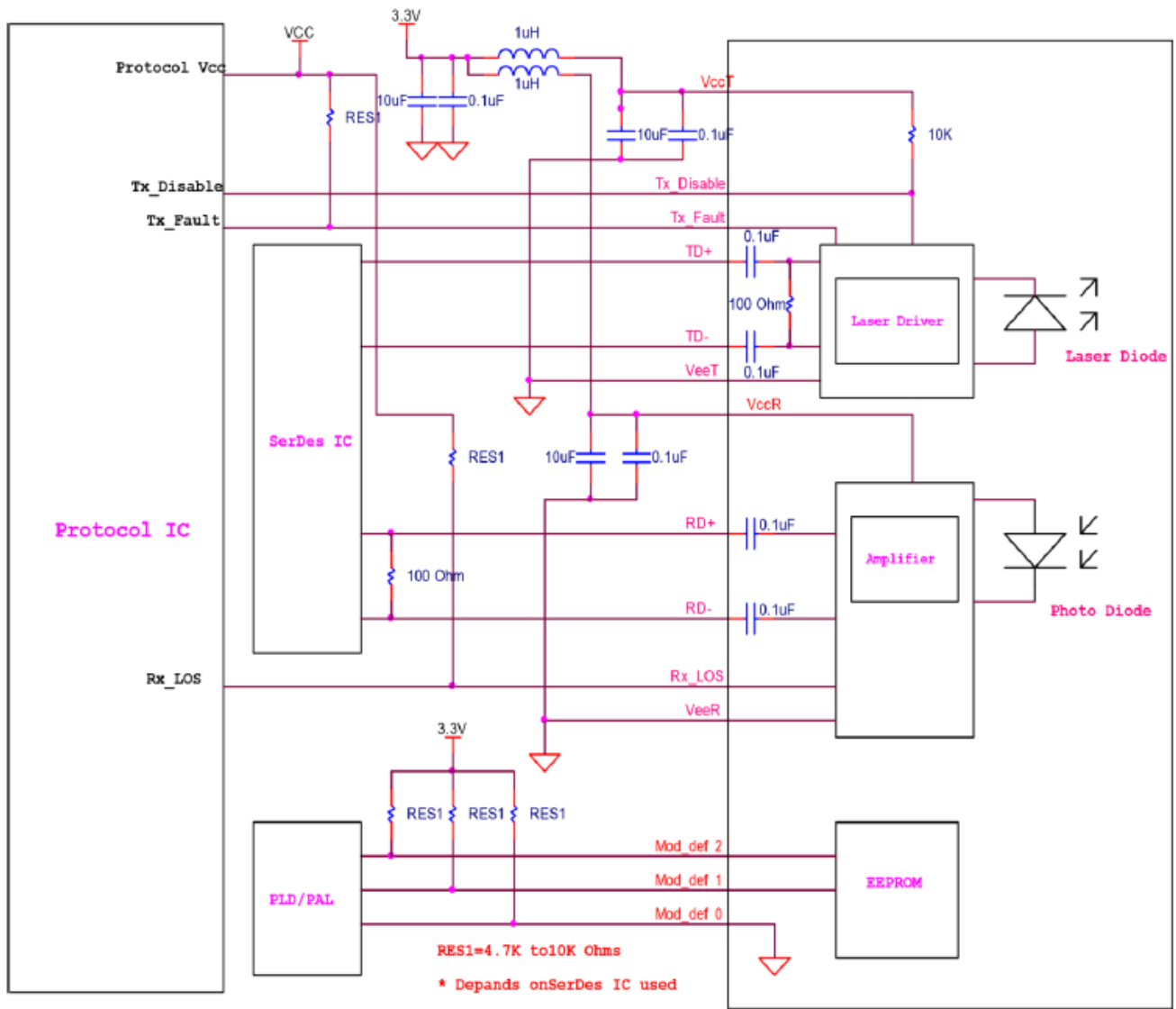

## IX. Mechanical Specifications (Unit: mm)

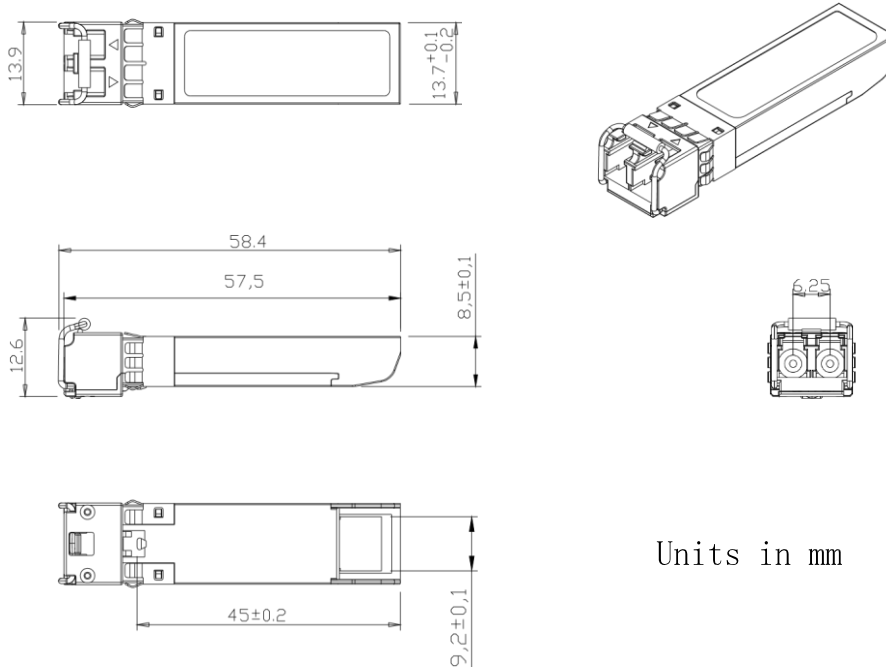

Units in mm

## SFP-1G-85-550M-D(I)

## X. Regulatory Compliance

Feature	Reference	Performance
Electrostatic discharge (ESD)	IEC/EN 61000-4-2	Compatible with standards
Electromagnetic Interference (EMI)	FCC Part 15 Class B EN 55022 Class B (CISPR 22A)	Compatible with standards
Laser Eye Safety	FDA 21CFR 1040.10, 1040.11 IEC/EN 60825-1, 2	Class 1 laser product
Component Recognition	IEC/EN 60950 , UL	Compatible with standards
ROHS	2002/95/EC	Compatible with standards
EMC	EN61000-3	Compatible with standards

INDONESIA OFFICE **NEW**  
WEST PARK B-23  
JL. BLVD. BARAT BSD CITY  
PAGEDANGAN, TANGERANG  
BANTEN 15336  
+62 2 150 858 721

HEAD OFFICE AND R&D LAB  
UNIT 1 / 6 POWELLS ROAD  
BROOKVALE, SYDNEY  
NSW 2100 AUSTRALIA  
 +61 2 8078 2207

MELBOURNE OFFICE  
11 CORPORATE DRIVE  
CRANBOURNE WEST  
VIC 3977 AUSTRALIA  
 +61 3 8679 4575

USA R&D LAB  
48233  
WARM SPRINGS BLVD.  
FREMONT CA  
 +1 510 945 1001  
 +1 510 298 5772